

FLANGED FITTINGS

*Elbows
Tees
Crosses
Wyes
Reducers
Flanges
Converters
Gaskets
Nuts & Bolts*

AWWA C110 Class 250

3"~24"

ANSI B16.1 Class 125

2"~12"



UNITED Water 
Products

UNITED BRAND FITTINGS

Our dedication to the mechanical piping industry has given us the opportunity to provide you with a quality comprehensive line of flanged fittings exceeding competitive brands.

Our flanged fitting series are available in 2"~24" sizes in a variety of elbows, tees, crosses, laterals, reducers, and blind flanges. All are manufactured in strict accordance with ANSI B16.1 (2"~12") and AWWA C110 Class 250 (3"~24")

Material: Ductile Cast Iron, ASTM A536, Grey Cast Iron, ASTM A-126

Flange: Faced and drilled in accordance with ANSI B16.1 Class 125

FLANGE DETAILS - Class 125

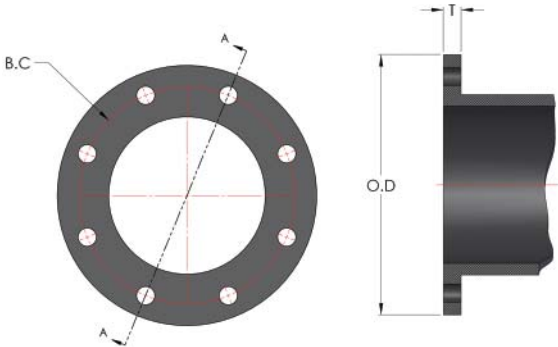

Size	O.D.	B.C.	T	Bolt Hole Dia.	Bolt Dia. & Length	No. of Bolts
2	6.00	4.75	5/8	3/4	5/8 x 2-1/2	4
2-1/2	7.00	5.0	11/16	3/4	5/8 x 2-1/2	4
3	7.50	6.00	3/4	3/4	5/8 x 2-1/2	4
4	9.00	7.50	15/16	3/4	5/8 x 3	8
5	10.00	8.50	15/16	7/8	3/4 x 3-1/2	8
6	11.00	9.50	1	7/8	3/4 x 3-1/2	8
8	13.50	11.75	1-1/8	7/8	3/4 x 3-1/2	8
10	16.00	14.25	1-3/16	1	7/8 x 4	12
12	19.00	17.00	1-1/4	1	7/8 x 4	12
14	21.00	18.75	1/3/8	1-1/8	1 x 4-1/2	12
16	23.50	21.25	1-7/16	1-1/8	1 x 4-1/2	16
18	25.00	22.75	1-9/16	1-1/4	1-1/8 x 5	16
20	27.50	25.00	1-11/16	1-1/4	1-1/8 x 5	20
24	32.00	29.50	1-7/8	1-3/8	1-1/4 x 5-1/2	20

All dimensional data in inches and lbs.

ELBOWS

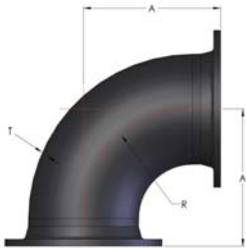

SERIES 10
90°

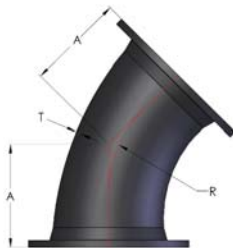

SERIES 11
45°

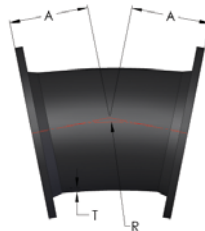

SERIES 12
22 1/2°



SERIES 13
11 1/4°

Size	90° Elbow				45° Elbow				22 1/2° Elbow				11 1/4° Elbow				T	
	Part No.	A	R	Wgt.	Part No.	A	R	Wgt.	Part No.	A	R	Wgt.	Part No.	A	R	Wgt.		
2	10F-0202-	4.5	3.0	14	11F-0202-	2.5	2.4	12	-	-	-	-	-	-	-	-	-	.31
2-1/2	10F-025025-	5.0	3.5	19	11F-025025-	3.0	3.6	17	-	-	-	-	-	-	-	-	-	.31
3	10F-0303-	5.5	4.0	25	11F-0303-	3.0	3.6	20	12F-0303-	3.0	7.6	20	13F-0303-	3.0	15.25	20	-	.38
4	10F-0404-	6.5	4.5	45	11F-0404-	4.0	4.8	40	12F-0404-	4.0	10.06	40	13F-0404-	4.0	20.31	40	-	.50
5	10F-0505-	7.5	5.5	52	11F-0505-	4.5	6.0	45	-	-	-	-	-	-	-	-	-	.50
6	10F-0606-	8.0	6.0	65	11F-0606-	5.0	7.3	55	12F-0606-	5.0	15.06	55	13F-0606-	5.0	30.50	55	-	.56
8	10F-0808-	9.0	7.0	105	11F-0808-	5.5	8.4	90	12F-0808-	5.5	17.62	90	13F-0808-	5.5	35.50	90	-	.62
10	10F-1010-	11.0	9.0	165	11F-1010-	6.5	10.9	130	12F-1010-	6.5	22.62	135	13F-1010-	6.5	45.69	135	-	.75
12	10F-1212-	12.0	10.0	235	11F-1212-	7.5	13.3	195	12F-1212-	7.5	27.62	205	13F-1212-	7.5	55.81	205	-	.81
14	10F-1414-	14.0	11.5	290	11F-1414-	7.5	12.06	220	-	-	-	-	-	-	-	-	-	.66
16	10F-1616-	15.0	12.5	370	11F-1616-	8.0	13.25	280	-	-	-	-	-	-	-	-	-	.70
18	10F-1818-	16.5	14.0	450	11F-1818-	8.5	14.50	325	-	-	-	-	-	-	-	-	-	.75
20	10F-2020-	18.0	15.5	580	11F-2020-	9.5	16.88	430	-	-	-	-	-	-	-	-	-	.80
24	10F-2424-	22.0	18.5	900	11F-2424-	11.0	18.12	630	-	-	-	-	-	-	-	-	-	.89

90° REDUCING ELBOW

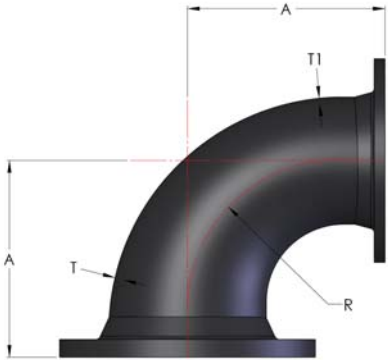

SERIES 10R

Size	Part No.	A	R	T	T1	Weight
3 x 2	10F-0302-	5.5	4.0	.38	.31	19
3 x 2-1/2	10F-03025-	5.5	4.0	.38	.31	22
4 x 2	10F-0402-	6.5	4.0	.50	.31	29
4 x 2-1/2	10F-04025-	6.5	4.0	.50	.31	31
4 x 3	10F-0403-	6.5	4.5	.50	.38	33
5 x 3	10F-0503-	7.5	5.0	.50	.50	44
5 x 4	10F-0504-	7.5	5.0	.50	.50	48
6 x 3	10F-0603-	8.0	6.0	.56	.38	45
6 x 4	10F-0604-	8.0	6.0	.56	.50	55
6 x 5	10F-0605-	8.0	6.0	.56	.50	65
8 x 4	10F-0804-	9.0	7.0	.62	.50	75
8 x 5	10F-0805-	9.0	7.0	.62	.56	80
8 x 6	10F-0806-	9.0	7.0	.62	.56	85
10 x 4	10F-1004-	11.0	9.0	.75	.50	110
10 x 6	10F-1006-	11.0	9.0	.75	.56	135
10 x 8	10F-1008-	11.0	9.0	.75	.62	150
12 x 4	10F-1204-	12.0	10.0	.81	.50	140
12 x 6	10F-1206-	12.0	10.0	.81	.56	160
12 x 8	10F-1208-	12.0	10.0	.81	.62	180
12 x 10	10F-1210-	12.0	10.0	.81	.75	210
14 x 10	10F-1410-	14.0	11.5	.66	.68	240
14 x 12	10F-1412-	14.0	11.5	.66	.75	270
16 x 10	10F-1610-	15.0	12.5	.70	.68	285
16 x 12	10F-1612-	15.0	12.5	.70	.75	310
16 x 14	10F-1614-	15.0	12.5	.70	.66	330

Add suffix "C" for Grey Cast Iron - "D" for Ductile Cast Iron

Larger sizes thru 48" available upon request.

90° LONG RADIUS ELBOW

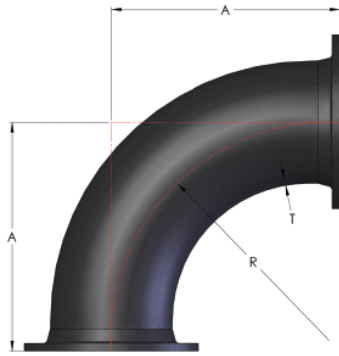

SERIES 15

Size	Part No.	B	R	T	Weight
2	15F-0202-	6.5	5.0	.31	16
2-1/2	15F-025025-	7.0	5.5	.31	23
3	15F-0303-	7.5	6.0	.38	28
4 x 3	15F-0403-	9.0	7.0	.48	38
4	15F-0404-	9.0	7.0	.50	48
6 x 4	15F-0604-	11.5	9.5	.55	70
6	15F-0606-	11.5	9.5	.56	85
8 x 6	15F-0806-	14.0	12.0	.60	116
8	15F-0808-	14.0	12.0	.62	145
10	15F-1010-	16.5	14.0	.75	230
12	15F-1212-	19.0	17.0	.81	350

90° BASE ELBOW

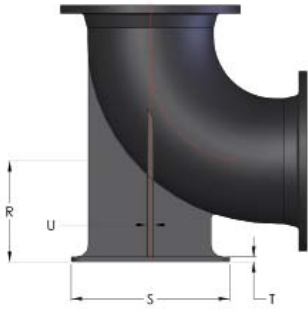

SERIES 16

Size	Part No.	R	S (Dia.)	T	U	Weight
3	16F-0303-	4.0	5.0	.28	.50	36
4	16F-0404-	5.5	6.0	.62	.50	55
6	16F-0606-	7.0	7.0	.69	.62	85
8	16F-0808-	8.38	9.0	.94	.88	145
10	16F-1010-	9.75	9.0	.94	.88	210
12	16F-1212-	11.25	11.0	1.0	1.0	300
14	16F-1414-	12.50	11.0	1.0	1.0	360
16	16F-1616-	13.75	11.0	1.0	1.0	445

SIDE OUTLET 90° ELBOW

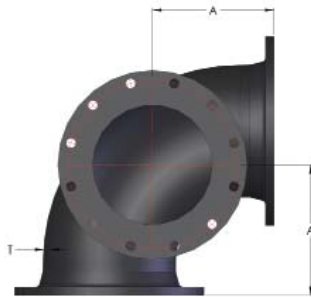

SERIES 18

Size	Part No.	A	R	T	Weight
4	18F-0404-	6.5	6.5	.50	60
6	18F-0606-	8.0	8.0	.56	95
8	18F-0808-	9.0	9.0	.62	150
10	18F-1010-	11.0	11.0	.75	235
12	18F-1212-	12.0	12.0	.81	335

SIDE OUTLET TEE

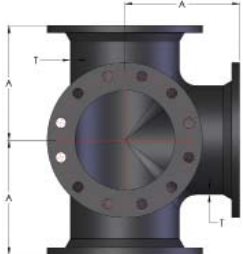

SERIES 19

Size	Part No.	A	T	Weight
4	19F-0404-	6.5	.50	80
6	19F-0606-	8.0	.56	135
8	19F-0808-	9.0	.62	210
10	19F-1010-	11.0	.75	330
12	19F-1212-	12.0	.81	470

Add suffix "C" for Grey Cast Iron - "D" for Ductile Cast Iron

Larger sizes thru 48" available upon request.

TEES & CROSSES

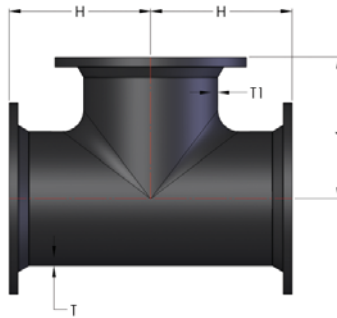

SERIES 20

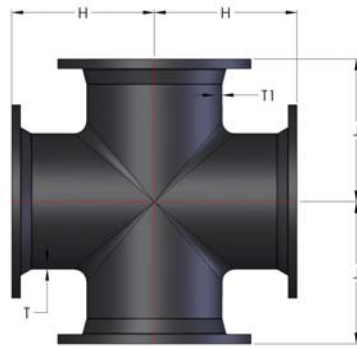

SERIES 35

Size	Part No.		H	J	T	T1	Weight	
	Tee	Cross					Tee	Cross
2	20F-0202-	35F-0202-	4.5	4.5	.31	.31	20	30
2-1/2	20F-025025-	35F-025025-	5.0	5.0	.31	.31	30	39
3 x 2	20F-0302-	-	5.5	5.5	.38	.31	35	-
3 x 2-1/2	20F-03025-	-	5.5	5.5	.38	.31	38	-
3	20F-0303-	35F-0303-	5.5	5.5	.38	.31	40	50
4 x 2	20F-0402-	-	6.5	6.5	.50	.31	50	-
4 x 2-1/2	20F-04025-	-	6.5	6.5	.50	.31	55	-
4 x 3	20F-0403-	-	6.5	6.5	.50	.38	60	-
4	20F-0404-	35F-0404-	6.5	6.5	.50	.50	65	80
5	20F-0505-	35F-0505-	7.5	7.5	.50	.50	85	105
6 x 2	20F-0602-	-	8.0	8.0	.56	.31	86	-
6 x 3	20F-0603-	-	8.0	8.0	.56	.38	85	-
6 x 4	20F-0604-	35F-0604-	8.0	8.0	.56	.50	90	110
6 x 5	20F-0605-	-	8.0	8.0	.56	.53	92	-
6	20F-0606-	35F-0606-	8.0	8.0	.56	.56	95	120
8 x 3	20F-0803-	-	9.0	9.0	.62	.38	140	-
8 x 4	20F-0804-	-	9.0	9.0	.62	.50	140	155
8 x 6	20F-0806-	35F-0806-	9.0	9.0	.62	.56	145	165
8	20F-0808-	35F-0808-	9.0	9.0	.62	.62	155	195
10 x 3	20F-1003-	-	11.0	11.0	.75	.38	200	-
10 x 4	20F-1004-	-	11.0	11.0	.75	.50	205	-
10 x 6	20F-1006-	-	11.0	11.0	.75	.56	215	240
10 x 8	20F-1008-	-	11.0	11.0	.75	.62	225	265
10	20F-1010-	35F-1010-	11.0	11.0	.75	.75	270	330
12 x 4	20F-1204-	-	12.0	12.0	.81	.50	290	-
12 x 6	20F-1206-	-	12.0	12.0	.81	.56	295	320
12 x 8	20F-1208-	-	12.0	12.0	.81	.62	310	345
12 x 10	20F-1210-	-	12.0	12.0	.81	.75	360	415
12	20F-1212-	35F-1212-	12.0	12.0	.81	.81	385	460
14	20F-1414-	35F-1414-	14.0	14.0	.66	.66	435	595
16	20F-1616-	35F-1616-	15.0	15.0	.70	.70	550	755
18	20F-1818-	35F-1818-	16.5	16.5	.75	.75	665	915
20	20F-2020-	35F-2020-	18.0	18.0	.80	.80	855	1175
24	20F-2424-	35F-2424-	22.0	22.0	.89	.89	1330	1850

REDUCING TEE (on Run and/or Branch)

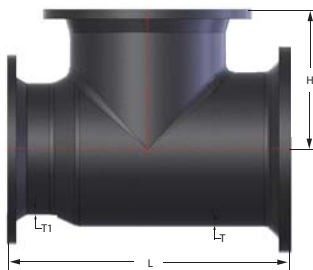

SERIES 26

Size	Part No.	H	L	T	T1	Weight
4 x 3 x 4	26F-0434-	6.5	13.0	.50	.38	59
6 x 4 x 4	26F-0644-	8.0	16.0	.56	.50	90
6 x 4 x 6	26F-0646-	8.0	16.0	.56	.50	95
8 x 4 x 8	26F-0848-	9.0	18.0	.62	.50	146
8 x 6 x 4	26F-0864-	9.0	18.0	.62	.56	125
8 x 6 x 6	26F-0866-	9.0	18.0	.62	.56	145
8 x 6 x 8	26F-0868-	9.0	18.0	.62	.56	160
10 x 8 x 8	26F-1088-	11.0	22.0	.75	.62	232
10 x 8 x 10	26F-10810-	11.0	22.0	.75	.62	262
12 x 8 x 8	26F-1288-	12.0	24.0	.81	.62	298
12 x 10 x 10	26F-121010-	12.0	24.0	.81	.75	340
12 x 10 x 12	26F-121012-	12.0	24.0	.81	.75	365

Add suffix "C" for Grey Cast Iron - "D" for Ductile Cast Iron

Larger sizes thru 48" available upon request.

BULLHEAD TEE

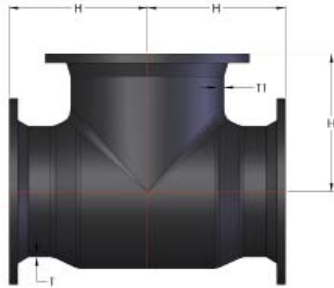

SERIES 27

Size	Part No.	H	J	T	T1	Weight
4 x 4 x 6	27F-446-	8.0	8.0	.50	.56	88
6 x 6 x 8	27F-668-	9.0	9.0	.56	.62	142
8 x 8 x 10	27F-8810-	11.0	11.0	.62	.75	240
10 x 10 x 12	27F-101012-	12.0	12.0	.75	.81	340

TRUE WYES



SERIES 32

Size	Part No.	A	B	T	Weight
4	32F-0404-	6.5	3.0	.50	50
6	32F-0606-	8.0	3.5	.56	80
8	32F-0808-	9.0	4.5	.62	125

LATERAL WYES

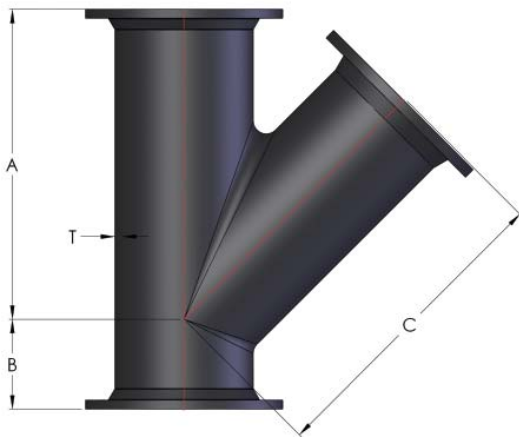

SERIES 30

Size	Part No.	A	B	C	T	Weight
3	30F-0303-	10.0	3.0	10.0	.38	45
4 x 3	30F-0403-	12.0	3.0	12.0	.52	65
4	30F-0404-	12.0	3.0	12.0	.50	75
6 x 3	30F-0603-	14.5	3.0	12.0	.55	100
6 x 4	30F-0604-	14.5	3.5	14.5	.56	105
6	30F-0606-	14.5	3.5	14.5	.56	120
8 x 6	30F-0806-	17.5	4.5	17.5	.62	175
8	30F-0808-	17.5	4.5	17.5	.62	200
10 x 6	30F-1006-	20.5	5.0	20.5	.68	270
10 x 8	30F-1008-	20.5	5.0	20.5	.68	295
10	30F-1010-	20.5	5.0	20.5	.75	335
12 x 6	30F-1206-	24.5	5.5	24.5	.75	395
12 x 8	30F-1208-	24.5	5.5	24.5	.75	420
12 x 10	30F-1210-	24.5	5.5	24.5	.75	455
12	30F-1212-	24.5	5.5	24.5	.81	515

CONCENTRIC & ECCENTRIC REDUCERS

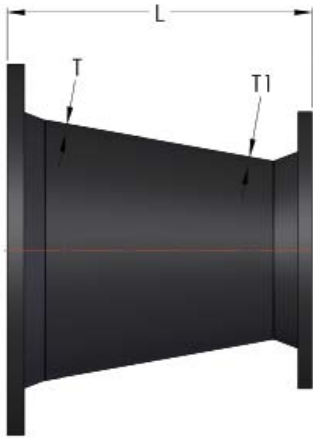

**(CONCENTRIC)
SERIES 50**

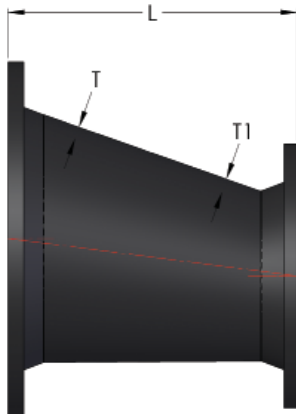

**(ECCENTRIC)
SERIES 51**

Size	Part No. (Concentric)	Part No. (Eccentric)	L	T	T1	Weight
2 x 1-1/2	50F-02015-	-	5.5	.31	.30	12
2-1/2 x 2	50F-02502-	-	5.5	.31	.31	14
3 x 1-1/2	50F-03015-	-	6	.38	.30	15
3 x 2	50F-0302-	51F-0302-	6	.38	.31	16
3 x 2-1/2	50F-03025-	51F-03025-	6	.38	.31	20
4 x 2	50F-0402-	51F-0402-	7	.50	.31	25
4 x 2-1/2	50F-04025-	51F-04025-	7	.50	.31	28
4 x 3	50F-0403-	51F-0403-	7	.50	.38	30
5 x 2-1/2	50F-05025-	51F-05025-	8	.50	.31	31
5 x 3	50F-0503-	51F-0503-	8	.50	.38	32
5 x 4	50F-0504-	51F-0504-	8	.50	.50	39
6 x 2	50F-0602-	51F-0602-	9	.56	.31	35
6 x 2-1/2	50F-06025-	51F-06025-	9	.56	.31	38
6 x 3	50F-0603-	51F-0603-	9	.56	.38	40
6 x 4	50F-0604-	51F-0604-	9	.56	.50	45
6 x 5	50F-0605-	51F-0605-	9	.56	.50	50
8 x 3	50F-0803-	51F-0803-	11	.62	.38	57
8 x 4	50F-0804-	51F-0804-	11	.62	.50	65
8 x 5	50F-0805-	51F-0805-	11	.62	.50	70
8 x 6	50F-0806-	51F-0806-	11	.62	.56	75
10 x 4	50F-1004-	51F-1004-	12	.75	.50	85
10 x 5	50F-1005-	51F-1005-	12	.75	.50	88
10 x 6	50F-1006-	51F-1006-	12	.75	.56	90
10 x 8	50F-1008-	51F-1008-	12	.75	.62	110
12 x 4	50F-1204-	51F-1204-	14	.81	.50	120
12 x 6	50F-1206-	51F-1206-	14	.81	.56	130
12 x 8	50F-1208-	51F-1208-	14	.81	.62	145
12 x 10	50F-1210-	51F-1210-	14	.81	.75	170
14 x 6	50F-1406-	51F-1406-	16	.66	.55	155
14 x 8	50F-1408-	51F-1408-	16	.66	.60	175
14 x 10	50F-1410-	51F-1410-	16	.66	.68	190
14 x 12	50F-1412-	51F-1412-	16	.66	.75	220
16 x 6	50F-1606-	51F-1606-	18	.70	.55	190
16 x 8	50F-1608-	51F-1608-	18	.70	.60	210
16 x 10	50F-1610-	51F-1610-	18	.70	.68	235
16 x 12	50F-1612-	51F-1612-	18	.70	.75	265
16 x 14	50F-1614-	51F-1614-	18	.70	.66	280
18 x 8	50F-1808-	51F-1808-	19	.75	.60	240
18 x 10	50F-1810-	51F-1810-	19	.75	.68	265
18 x 12	50F-1812-	51F-1812-	19	.75	.75	295
18 x 14	50F-1814-	51F-1814-	19	.75	.66	310
18 x 16	50F-1816-	51F-1816-	19	.75	.70	340
20 x 10	50F-2010-	51F-2010-	20	.80	.68	310
20 x 12	50F-2012-	51F-2012-	20	.80	.75	345
20 x 14	50F-2014-	51F-2014-	20	.80	.66	355
20 x 16	50F-2016-	51F-2016-	20	.80	.70	390
20 x 18	50F-2018-	51F-2018-	20	.80	.75	410
24 x 12	50F-2412-	51F-2412-	24	.89	.75	480
24 x 14	50F-2414-	51F-2414-	24	.89	.66	490
24 x 16	50F-2416-	51F-2416-	24	.89	.70	525
24 x 18	50F-2418-	51F-2418-	24	.89	.75	550
24 x 20	50F-2420-	51F-2420-	24	.89	.80	590

Add suffix "C" for Grey Cast Iron - "D" for Ductile Cast Iron

Larger sizes thru 48" available upon request.

STANDARD COMPANION FLANGE (Cast Iron)

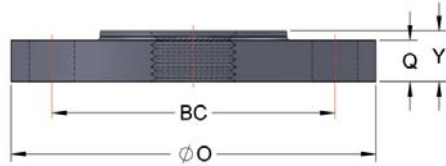

SERIES 306

Nominal Size	Product No.	BC	O	Q	Y	Bolt Holes		Wgt.
						No.	Size	
1	306-100-0425	3.12	4-1/4	7/16	11/16	4	0.62	1.75
1-1/4	306-125-0463	3.50	4-5/8	1/2	13/16	4	0.62	2.00
1-1/2	306-150-0500	3.88	5	9/16	7/8	4	0.62	2.25
2	306-200-0600	4.75	6	5/8	1	4	0.75	4.00
2-1/2	306-250-0700	5.50	7	11/16	1-1/8	4	0.75	6.00
3	306-300-0750	6.00	7-1/2	3/4	1-3/16	4	0.75	7.63
3-1/2	306-350-0850	7.00	8-1/2	13/16	1-1/4	8	0.75	9.50
4	306-400-0900	7.50	9	15/16	1-5/16	8	0.75	11.75
5	306-500-1000	8.50	10	15/16	1-7/16	8	0.88	14.00
6	306-600-1100	9.50	11	1	1-9/16	8	0.88	16.50
8	306-800-1350	11.75	13-1/2	1-1/8	1-3/4	8	0.88	26.00
10	306-1000-1600	14.25	16	1-3/16	1-15/16	12	1.00	38.00
12	306-1200-1900	17.00	19	1-1/4	2-3/16	12	1.00	51.00

REDUCING COMPANION FLANGE (Cast Iron)

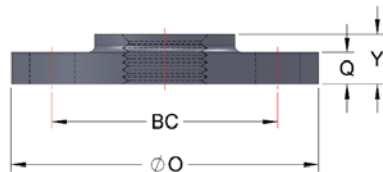

SERIES 316

Nominal Size		Product No.	Thread Size	BC	O	Q	Y	Bolt Holes		Weight
Pipe x O.D.	Flg. x Pipe							No.	Size	
1 x 5	1-1/2 x 1	316-100-0500	1	3.88	5	9/1	11/16	4	0.62	2.75
1-1/4 x 5	1-1/2 x 1-1/4	316-125-0500	1-1/4				13/16			2.50
1 x 6	2 x 1	316-100-0600	1	4.75	6	5/8	11/16	4	0.75	5.00
1-1/4 x 6	2 x 1-1/4	316-125-0600	1-1/4				13/16			4.75
1-1/2 x 6	2 x 1-1/2	316-150-0600	1-1/2				7/8			4.50
1-1/2 x 7	2-1/2 x 1-1/2	316-150-0700	1-1/2	5.50	7	11/16	7/8	4	0.75	7.00
2 x 7	2-1/2 x 2	316-200-0700	2				1			6.75
1 x 7-1/2	3 x 1	316-100-0750	1				13/16			9.00
1-1/2 x 7-1/2	3 x 1-1/2	316-150-0750	1-1/2	6.00	7-1/2	3/4	7/8	4	0.75	8.75
2 x 7-1/2	3 x 2	316-200-0750	2				1			8.50
2-1/2 x 7-1/2	3 x 2-1/2	316-250-0750	2-1/2				1-1/8			8.00
1-1/2 x 9	4 x 1-1/2	316-150-0900	1-1/2				1			14.75
2 x 9	4 x 2	316-200-0900	2				1			14.00
2-1/2 x 9	4 x 2-1/2	316-250-0900	2-1/2	7.50	9	15/16	1-1/8	8	0.75	13.50
3 x 9	4 x 3	316-300-0900	3				1-3/16			12.75
2 x 10	5 x 2	316-200-1000	2				1			18.00
3 x 10	5 x 3	316-300-1000	3	8.50	10	15/16	1-3/16	8	0.88	17.00
4 x 10	5 x 4	316-400-1000	4				1-5/16			16.00
1-1/2 x 11	6 x 1-1/2	316-150-1100	1-1/2				1-1/16			27.00
2 x 11	6 x 2	316-200-1100	2				1-1/16			26.00
2-1/2 x 11	6 x 2-1/2	316-250-1100	2-1/2	9.50	11	1	1-1/8	8	0.88	25.00
3 x 11	6 x 3	316-300-110	3				1-3/16			23.00
4 x 11	6 x 4	316-400-1100	4				1-5/16			21.00
5 x 11	6 x 5	316-500-1100	5				1-7/16			19.00
2 x 13-1/2	8 x 2	316-200-1350	2				1-3/16			4.00
3 x 13-1/2	8 x 3	316-300-1350	3				1-3/16			40.00
4 x 13-1/2	8 x 4	316-400-1350	4	11.75	13-1/2	1-1/8	1-5/16	8	0.88	37.00
5 x 13-1/2	8 x 5	316-500-1350	5				1-7/16			34.00
6 x 13-1/2	8 x 6	316-600-1350	6				1-9/16			31.00
2 x 16	10 x 2	316-200-1600	2				1-15/16			61.00
4 x 16	10 x 4	316-400-1600	4	14.25	16	1-3/16	1-15/16	12	1.00	57.00
6 x 16	10 x 6	316-600-1600	6				1-15/16			53.00
8 x 16	10 x 8	316-800-1600	8				1-15/16			50.00
2 x 19	12 x 2	316-200-1900	2				2-3/16			84.00
4 x 19	12 x 4	316-400-1900	4				2-3/16			86.00
6 x 19	12 x 6	316-600-1900	6	17.00	19	1-1/4	2-3/16	12	1.00	88.00
8 x 19	12 x 8	316-800-1900	8				2-3/16			81.00
10 x 19	12 x 10	316-1000-1900	10				2-3/16			72.00

Add suffix "C" for Grey Cast Iron - "D" for Ductile Cast Iron

Larger sizes thru 48" available upon request.

REDI-FLANGE™

**No Welding!
No Threading!**

STANDARDS:

Ductile Iron - ASTM A536
Grade 65-45-12. Drilling to
ANSI B16.1 - 125 lb.
ANSI B16.5 - 150 lb.

SET SCREW: AISI

steel. Tensile 160,000
psi minimum.

GASKET: SBR (BUNA-N).

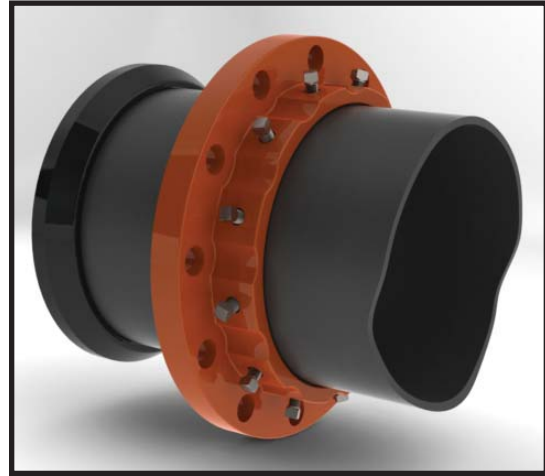

HYDROSTATIC TEST

PRESSURE:

MODEL - RFC-2 - 125 lb./150 lb.
2 in. - 8 in. 600 psi
10 in. - 12 in. 525 psi

MODEL - RFC-4 - 125 lb./150 lb.
14 in. - 24 in. 300 psi

The *Redi-Flange™* joins valves, fittings and equipment with integral flanged ends to plain end pipe, without the need of pipe end preparation. Absolutely no threading, welding, or grooving is necessary. The working principle of the *Redi-Flange™* is relatively simple. Slide the flange over plain end pipe and follow it with a standard mechanical joint gasket. When the *Redi-Flange™* is brought to mate against an existing flange, and the flange bolts are tightened, a compression type seal is created against the mating flange and pipe surface. End restraint is provided when the set screws are tightened.

Nom. Pipe Size	Part No.	D.I. Pipe O.D. RFC-2-	Steel Pipe O.D. RFC-2-S	Flange O.D.	Bolt Circle	Bolt Hole Dia.	Set Screws		Wgt. Approx.
							No.	Size	
2	RFC-201	2.50	2.38	6	4-3/4	3/4	2	1/2 x 1	3.5
2-1/2	RFC-202	-	2.88	7	5-1/2	3/4	4	1/2 x 1	4
3	RFC-203	3.96	3.50	7-1/2	6	3/4	4	1/2 x 1	5
4	RFC-204	4.80	4.50	9	7-1/2	3/4	4	1/2 x 1	8
5	RFC-205	-	5.56	10	8-1/2	7/8	8	1/2 x 1	9
6	RFC-206	6.90	6.625	11	9-1/2	7/8	8	1/2 x 1	10
8	RFC-208	9.05	8.625	13-1/2	11-3/4	7/8	8	5/8 x 1-1/4	17
10	RFC-210	11.10	10.75	16	14-1/4	1	12	5/8 x 1-1/4	22
12	RFC-212	13.20	12.75	19	17	1	12	5/8 x 1-1/4	31

Nom. Pipe Size	Part No.	D.I. Pipe O.D. RFC-4-	Flange O.D.	Bolt Circle	Boly Hole Dia.	Set Screws		Wgt. Approx.
						No.	Size	
14	RFC-414	15.30	21	18-3/4	1-1/8	12	5/8 x 1-1/4	70
16	RFC-416	17.40	23-1/2	21-1/4	1-1/8	16	5/8 x 1-1/4	79
18	RFC-418	19.50	25	22-3/4	1-1/4	16	3/4 x 2	90
20	RFC-420	21.60	27-1/2	25	1-1/4	20	3/4 x 2	145
24	RFC-424	25.80	32	29-1/2	1-3/8	20	3/4 x 2	175
30	RFC-430	32.00	38-3/4	36	1-3/8	28	1 x 2-1/4	270
36	RFC-436	38.30	46	42-3/4	1-5/8	32	1 x 2-1/4	400

**COMPACT FLANGE
REDUCER
Class 125/150 Flanges**

Mates with ANSI Class 125/150 flange drillings
Material: Ductile Iron - ASTM A536 or ASTM A36 Steel

TYPE A

TYPE B

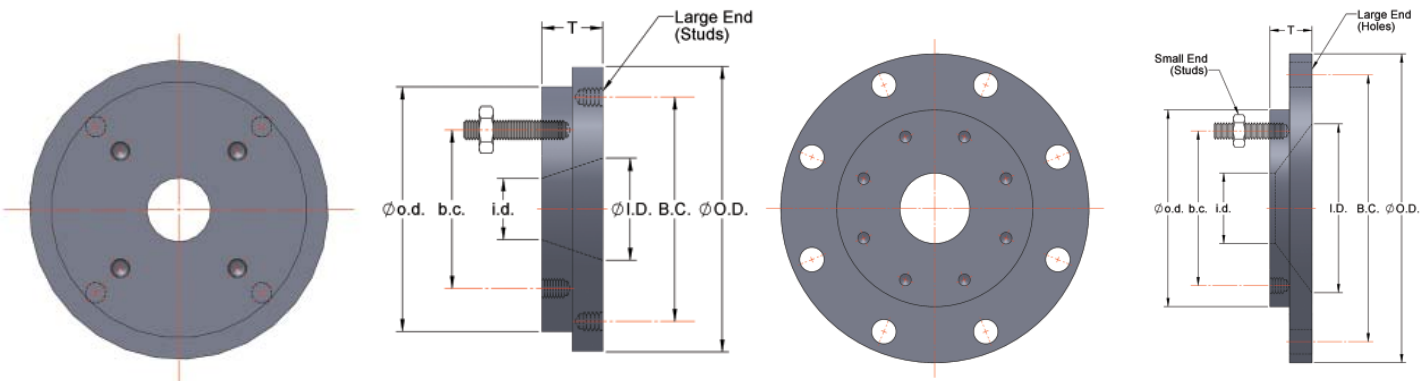

Flange Size	Part No.	Large End			Small End			T	Type	Large End Studs		Small End Studs	
		I.D.	O.D.	B.C.	i.d.	o.d.	b.c.			Qty.	Size	Qty.	Size
2 x 1-1/2	740-110-100	2.00	6.00	4.75	1.50	6.00	3.88	1.50	A	4	5/8 x 2-1/2	4	1/2 x 2-1/2
2 1/2 x 1-1/2	740-120-100	2.50	7.00	5.50	1.50	6.00	3.88	1.50	A	4	5/8 x 2-1/2	4	1/2 x 2-1/2
2 1/2 x 2	740-120-110	2.50	7.00	5.50	2.00	6.00	4.75	1.50	A	4	5/8 x 2-1/2	4	5/8 x 2-1/2
3 x 1-1/2	740-130-100	3.00	7.50	6.00	1.50	6.00	3.88	1.50	A	4	5/8 x 2-1/2	4	1/2 x 2-1/2
3 x 2	740-130-110	3.00	7.50	6.00	2.00	6.00	4.75	1.50	A	4	5/8 x 2-1/2	4	5/8 x 2-1/2
3 x 2-1/2	740-130-120	3.00	7.50	6.00	2.50	7.00	5.50	1.50	A	4	5/8 x 2-1/2	4	5/8 x 2-1/2
4 x 2	740-140-110	4.00	9.00	7.50	2.00	6.00	4.75	1.50	A	8	5/8 x 3	4	5/8 x 2-1/2
4 x 2-1/2	740-140-120	4.00	9.00	7.50	2.50	7.00	5.50	1.50	A	8	5/8 x 3	4	5/8 x 2-1/2
4 x 3	740-140-130	4.00	9.00	7.50	3.00	7.50	6.00	1.50	A	8	5/8 x 3	4	5/8 x 2-1/2
6 x 2-1/2	790-160-120	6.00	11.00	9.50	2.50	7.00	5.50	1.50	B	-	-	8	5/8 x 2-1/2
6 x 3	790-160-130	6.00	11.00	9.50	3.00	7.50	6.00	1.50	B	-	-	8	5/8 x 2-1/2
6 x 4	740-160-140	6.00	11.00	9.50	4.00	9.00	7.50	2.00	A	8	3/4 x 3-1/2	8	5/8 x 3
6 x 5	740-160-150	6.00	11.00	9.50	5.00	10.00	8.50	2.00	A	8	3/4 x 3-1/2	8	3/4 x 3-1/2
8 x 4	790-180-140	8.00	13.50	11.75	4.00	9.00	7.50	2.00	B	-	-	8	5/8 x 3
8 x 5	740-180-150	8.00	13.50	11.75	5.00	10.00	8.50	2.00	A	8	3/4 x 3-1/2	8	3/4 x 3-1/2
8 x 6	740-180-160	8.00	13.50	11.75	6.00	11.00	9.50	2.00	A	8	3/4 x 3-1/2	8	3/4 x 3-1/2
10 x 2	790-200-110	10.00	16.00	14.25	2.00	6.00	4.75	1.50	B	-	-	4	5/8 x 2-1/2
10 x 4	790-200-140	10.00	16.00	14.25	4.00	9.00	7.50	2.00	B	-	-	8	5/8 x 3
10 x 5	790-200-150	10.00	16.00	14.25	5.00	10.00	8.50	2.00	B	-	-	8	3/4 x 3-1/2
10 x 6	740-200-160	10.00	16.00	14.25	6.00	11.00	9.50	2.00	A	12	7/8 x 4	8	3/4 x 3-1/2
10 x 8	740-200-180	10.00	16.00	14.25	8.00	13.50	11.75	2.00	A	12	7/8 x 4	8	3/4 x 3-1/2
12 x 4	790-220-140	12.00	19.00	17.00	4.00	9.00	7.50	2.00	B	-	-	8	5/8 x 3
12 x 6	790-220-160	12.00	19.00	17.00	6.00	11.00	9.50	2.00	B	-	-	8	3/4 x 3-1/2
12 x 8	740-220-180	12.00	19.00	17.00	8.00	13.50	11.75	2.00	A	12	7/8 x 4	8	3/4 x 3-1/2
12 x 10	740-220-200	12.00	19.00	17.00	10.00	16.00	14.25	2.00	A	12	7/8 x 4	12	7/8 x 4
14 x 6	790-240-160	14.00	21.00	18.75	6.00	11.00	9.50	2.50	B	-	-	8	3/4 x 3-1/2
14 x 8	790-240-180	14.00	21.00	18.75	8.00	13.50	11.75	2.50	B	-	-	8	3/4 x 3-1/2
14 x 10	740-240-200	14.00	21.00	18.75	10.00	16.00	14.25	2.50	A	12	1 x 4-1/2	12	7/8 x 4
14 x 12	740-240-220	14.00	21.00	18.75	12.00	19.00	17.00	2.50	A	12	1 x 4-1/2	12	7/8 x 4
16 x 6	790-260-160	16.00	23.50	21.25	3.00	11.00	9.50	2.50	B	-	-	8	3/4 x 3-1/2
16 x 8	790-260-180	16.00	23.50	21.25	8.00	13.50	11.75	2.50	B	-	-	8	3/4 x 3-1/2
16 x 10	790-260-200	16.00	23.50	21.25	10.00	16.00	14.25	2.50	B	-	-	12	7/8 x 4
16 x 12	740-260-220	16.00	23.50	21.25	12.00	19.00	17.00	2.50	A	16	1 x 4-1/2	12	7/8 x 4
16 x 14	740-260-240	16.00	23.50	21.25	14.00	21.00	18.75	2.50	A	16	1 x 4-1/2	12	1 x 4-1/2
18 x 12	740-280-220	18.00	25.00	22.75	12.00	19.00	17.00	2.50	B	-	-	12	7/8 x 4
20 x 12	740-300-220	20.00	27.50	25.00	12.00	19.00	17.00	2.50	B	-	-	12	7/8 x 4

Add suffix "C" for Grey Cast Iron - "D" for Ductile Cast Iron Larger sizes thru 48" available upon request.

BLIND FLANGES



SERIES 60 (1"~10")

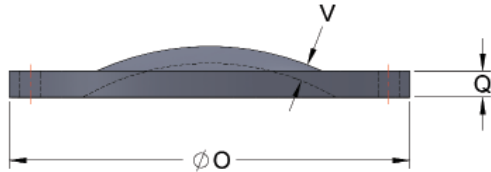

SERIES 60 (12")

Size	Part No.	O	Q	V	Weight
1	60F-0100-	4.25	.44	.38	2
1-1/4	60F-0125-	4.62	.50	.44	2.25
1-1/2	60F-0150-	5.00	.56	.50	3.75
2	60F-0200-	6.00	.62	.62	5
2-1/2	60F-0250-	7.00	.68	.62	7
3	60F-0300-	7.50	.75	.69	9
3-1/2	60F-0350-	8.50	.81	.75	14
4	60F-0400-	9.00	.94	.88	16
5	60F-0500-	10.00	.94	.88	18
6	60F-0600-	11.00	1.00	.94	25
8	60F-0800-	13.50	1.12	1.06	42
10	60F-1000-	16.00	1.19	1.12	62
12	60F-1200-	19.00	1.25	.81	85
14	60F-1400-	21.00	1.38	.88	120
16	60F-1600-	23.50	1.44	1.00	145
18	60F-1800-	25.00	1.56	1.06	185
20	60F-2000-	27.50	1.69	1.12	245
24	60F-2400-	32.00	1.88	1.25	370

FLANGE CONVERTERS

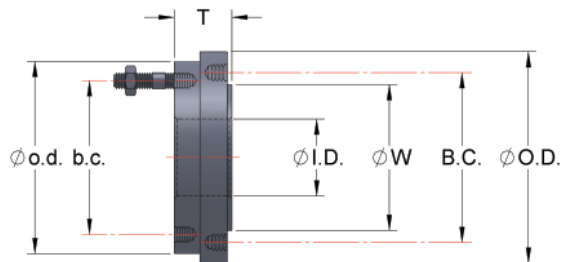

Class 125/150

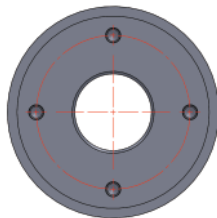

Class 250/300

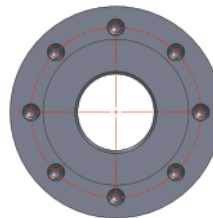

Part No.	CLASS 125/150					CLASS 250/300							Weight
	Flange Size/I.D.	o.d.	b.c.	No. of Bolt Holes	Stud Bolt Size	W	B.C.	O.D.	A	T	No. of Bolt Holes	Stud Bolt Size	
840-130	3	7.50	6.0	4	5/8 x 3	5.69	6.62	8.25	0.06	2	8	3/4 x 3-1/2	24
840-140	4	9	7.5	8	5/8 x 3	6.94	7.88	10	0.06	2	8	3/4 x 4	28
840-150	5	10	8.5	8	3/4 x 3-1/2	8.31	9.25	11	0.06	2	8	3/4 x 4	32
840-160	6	11	9.5	8	3/4 x 3-1/2	9.69	10.62	12.5	0.06	2	12	3/4 x 4	42
840-180	8	13.5	11.75	8	3/4 x 3-1/2	11.94	13	15	0.06	2 1/4	12	7/8 x 4-1/2	66
840-200	10	16	14.25	12	7/8 x 4	14.06	15.25	17.5	0.06	2 3/4	16	1 x 5-1/2	100
840-220	12	19	17	12	7/8 x 4	16.44	17.75	20.5	0.06	2 3/4	16	1-1/8 x 5-1/2	160

Add suffix "C" for Grey Cast Iron - "D" for Ductile Cast Iron

Larger sizes thru 48" available upon request.

DUCTILE IRON FLANGED PIPES

Integrally Cast

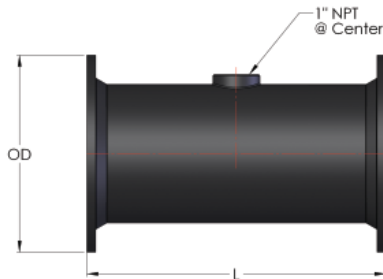
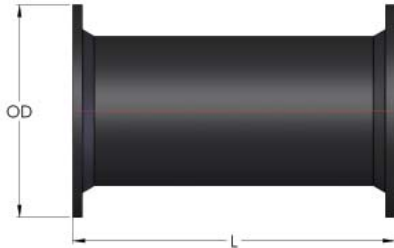

Part Number	Size (ND)	Length	Weight (Approx.)
80F-0406-	4"	6"	29.00
80F-0412-		12"	35.92
80F-0418-		18"	42.87
80F-0424-		24"	49.79
80F-0606-	6"	6"	41.10
80F-0612-		12"	52.19
80F-0618-		18"	63.28
80F-0624-		24"	74.37
80F-0806-	8"	6"	110.89
80F-0812-		12"	127.16
80F-0818-		18"	141.65
80F-0824-		24"	157.04

Raised Boss w/1" NPT

87F-0412-	4"	12"	36.00
87F-0612-	6"		52.00
87F-0812-	8"		127.16

FLANGE SPIGOT

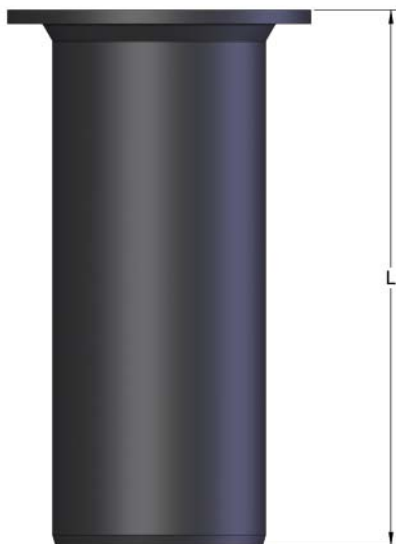

Part Number	Size (ND)	Length	Weight (Approx.)
56F-0448-	4"	48"	69
56F-0460-		60"	83
56F-0472-		72"	97
56F-0496-		96"	124
56F-0648-	6"	48"	105
56F-0660-		60"	126
56F-0672-		72"	147
56F-0696-		96"	190
56F-0848-	8"	48"	150
56F-0860-		60"	181
56F-0872-		72"	211
56F-0896-		96"	271

SEAL-TITE FLANGE GASKET

Low Torque!

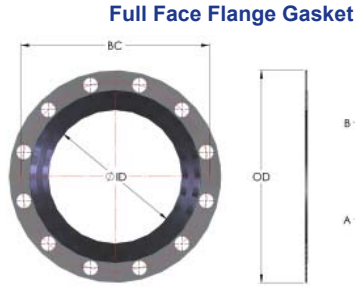

Ring Type Flange Gasket

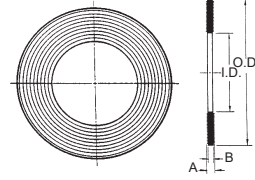

Serrated Face!

Material: SBR

Nominal Size	Part No. (Full Face)	Part No. (Ring)	ID	OD (Full Face)	OD (Ring)	A	B	BC (Full Face)	Box Quantity (Full Face)	Box Quantity (Ring)
2	FFG-050-150	RG-050-100	2.15	6.00	3.90	5/32	1/8	4.75	25	25
2 1/2	FFG-065-175	RG-065-120	2.73	7.00	4.70	5/32	1/8	5.50	25	25
3	FFG-080-188	RG-080-132	3.20	7.50	5.15	5/32	1/8	6.00	25	25
4	FFG-100-210	RG-100-162	3.98	9.00	6.30	5/32	1/8	7.50	25	25
5	FFG-125-250	RG-125-194	5.07	10.00	7.60	5/32	1/8	8.50	25	25
6	FFG-150-275	RG-150-218	6.01	11.00	8.50	5/32	1/8	9.50	25	25
8	FFG-200-340	RG-200-272	8.11	13.50	10.60	5/32	1/8	11.75	25	25
10	FFG-250-400	RG-250-328	10.06	16.00	12.80	5/32	1/8	14.25	25	25
12	FFG-300-475	RG-300-378	12.09	19.00	14.75	5/32	1/8	17.00	10	10
14	FFG-350-525	RG-350-445	14.12	21.00	17.15	5/32	1/8	18.75	10	10
16	FFG-400-588	RG-400-510	16.19	23.50	19.90	5/32	1/8	21.25	10	10
18	FFG-450-625	RG-450-542	18.25	25.00	21.15	5/32	1/8	22.75	10	10
20	FFG-500-688	RG-500-606	20.28	27.50	23.60	5/32	1/8	25.00	10	10
24	FFG-600-800	RG-600-717	24.34	32.00	27.95	5/32	1/8	29.50	10	10
30	FFG-750-985	-	30.98	38.75	-	5/32	1/8	36.00	5	-
36	FFG-900-1165	-	37.14	46.00	-	5/32	1/8	42.75	5	-

FLAT FLANGE GASKET

Full Face

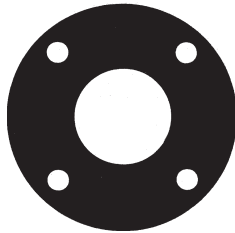

Ring Type

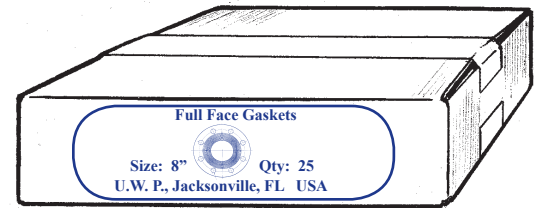

Material: Red Rubber
Non-Asbestos

Nominal Size	Part No. (Full Face)	Part No. (Ring)	OD (Full Face)	OD (Ring)	Thickness	Bolt Circle (Full Face)	Box Quantity (Full Face)	Box Quantity (Ring)
1	FFF-025-100	FRG-025-065	4.25	2.63	1/8	3.12	25	25
1-1/4	FFF-030-115	FRG-030-080	4.62	3.00	1/8	3.50	25	25
1-1/2	FFF-040-125	FRG-040-085	5.00	3.38	1/8	3.88	25	25
2	FFF-050-150	FRG-050-100	6.00	3.90	1/8	4.75	25	25
2 1/2	FFF-065-175	FRG-065-120	7.00	4.70	1/8	5.50	25	25
3	FFF-080-188	FRG-080-132	7.50	5.15	1/8	6.00	25	25
4	FFF-100-210	FRG-100-162	9.00	6.30	1/8	7.50	25	25
5	FFF-125-250	FRG-125-194	10.00	7.60	1/8	8.50	25	25
6	FFF-150-275	FRG-150-218	11.00	8.50	1/8	9.50	25	25
8	FFF-200-340	FRG-200-272	13.50	10.60	1/8	11.75	25	25
10	FFF-250-400	FRG-250-328	16.00	12.80	1/8	14.25	25	25
12	FFF-300-475	FRG-300-378	19.00	14.75	1/8	17.00	10	10
14	FFF-350-525	FRG-350-445	21.00	17.15	1/8	18.75	10	10
16	FFF-400-588	FRG-400-510	23.50	19.90	1/8	21.25	10	10
18	FFF-450-625	FRG-450-542	25.00	21.15	1/8	22.75	10	10
20	FFF-500-688	FRG-500-606	27.50	23.60	1/8	25.00	10	10
24	FFF-600-800	FRG-600-717	32.00	27.95	1/8	29.50	10	10
30	FFF-750-985	-	38.75	-	1/8	36.00	5	-
36	FFF-900-1165	-	46.00	-	1/8	42.75	5	-
42	FFF-1000-1345	-	53.00	-	1/8	49.50	5	-
48	FFF-1200-1510	-	59.50	-	1/8	56.00	5	-

FLANGE ACCESSORY PACKS

Class 125 & Class 250

Flanges



Class 125/150 Flange Size	1/8" Full Face Seal-Tite (Serrated)	1/8" Ring Type Seal-Tite (Serrated)	1/8" Full Face Red Rubber	1/8" Ring Type Red Rubber	1/8" Full Face Non-Asbestos	1/8" Ring Type Non-Asbestos
1	FBR-010-*	RBP-010-*	FRP-010-*	RRP-010-*	FNP-010-*	RNP-010-*
1-1/4	FBR-012-*	RBP-012-*	FRP-012-*	RRP-012-*	FNP-012-*	RNP-012-*
1-1/2	FBR-015-*	RBP-015-*	FRP-015-*	RRP-015-*	FNP-015-*	RNP-015-*
2	FBR-020-*	RBP-020-*	FRP-020-*	RRP-020-*	FNP-020-*	RNP-020-*
2-1/2	FBR-025-*	RBP-025-*	FRP-025-*	RRP-025-*	FNP-025-*	RNP-025-*
3	FBR-030-*	RBP-030-*	FRP-030-*	RRP-030-*	FNP-030-*	RNP-030-*
4	FBR-040-*	RBP-040-*	FRP-040-*	RRP-040-*	FNP-040-*	RNP-040-*
5	FBR-050-*	RBP-050-*	FRP-050-*	RRP-050-*	FNP-050-*	RNP-050-*
6	FBR-060-*	RBP-060-*	FRP-060-*	RRP-060-*	FNP-060-*	RNP-060-*
8	FBR-080-*	RBP-080-*	FRP-080-*	RRP-080-*	FNP-080-*	RNP-080-*
10	FBR-100-*	RBP-100-*	FRP-100-*	RRP-100-*	FNP-100-*	RNP-100-*
12	FBR-120-*	RBP-120-*	FRP-120-*	RRP-120-*	FNP-120-*	RNP-120-*
14	FBR-140-*	RBP-140-*	FRP-140-*	RRP-140-*	FNP-140-*	RNP-140-*
16	FBR-160-*	RBP-160-*	FRP-160-*	RRP-160-*	FNP-160-*	RNP-160-*
18	FBR-180-*	RBP-180-*	FRP-180-*	RRP-180-*	FNP-180-*	RNP-180-*
20	FBR-200-*	RBP-200-*	FRP-200-*	RRP-200-*	FNP-200-*	RNP-200-*
24	FBR-240-*	RBP-240-*	FRP-240-*	RRP-240-*	FNP-240-*	RNP-240-*
30	FBR-300-*	RBP-300-*	FRP-300-*	RRP-300-*	FNP-300-*	RNP-300-*
36	FBR-360-*	RBP-360-*	FRP-360-*	RRP-360-*	FNP-360-*	RNP-360-*
42	FBR-420-*	RBP-420-*	FRP-420-*	RRP-420-*	FNP-420-*	RNP-420-*
48	FBR-480-*	RBP-480-*	FRP-480-*	RRP-480-*	FNP-480-*	RNP-480-*

*Add suffix "Z" for Zinc Plated, "304" for 304 Stainless Steel & "316" for 316 Stainless Steel

*Add suffix "G" for Galvanized Steel

*Add suffix "250" for Zinc Class 250 Flange Accessories

Heavy Hex Bolts and Nuts for Flanges to B16.1-125#, B16.5-150#

Material: Bolts - ASTM A307 Grade B, Nuts -ASTM A563, Grade A

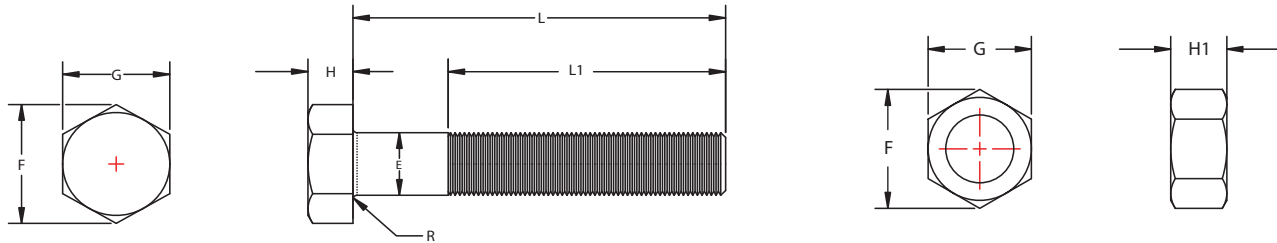

Nominal Size	Part No.	E	G	F	H	HI	R	L ₁	L
		Body Diamete	Width Across Flats	Max. Width Across Corners	Bolt Head Height	Nut Height	Radius of Fillet	Thread Length	Shaft Length
1/2 x 2	BN7025-050-200	0.515	7/8	1.010	11.32	31/64	0.01~0.03	1.25	2.00
5/8 x 2-1/2	BN7025-062-250	0.642	1-1/16	1.227	27/64	39/64	0.02~0.06	1.50	2.50
5/8 x 3	BN7025-062-300	0.642	1-1/16	1.227	27/64	39/64	0.02~0.06	1.50	3.00
3/4 x 3-1/2	BN7025-075-350	0.768	1-1/4	1.443	1/2	47/64	0.02~0.06	1.75	3.50
3/4 x 4-1/2	BN7025-075-450	0.768	1-1/4	1.443	1/2	47/64	0.02~0.06	1.75	4.50
7/8 x 4	BN7025-082-400	0.895	1-7/16	1.660	37/64	55/64	0.02~0.06	2.00	4.00
7/8 x 4-1/2	BN7025-082-450	0.895	1-7/16	1.660	37/64	55/64	0.02~0.06	2.00	4.50
1 x 4-1/2	BN7025-100-450	1.022	1-5/8	1.876	43/64	63/64	0.03~0.09	2.25	4.50
1 -1/8 x 5	BN7025-112-500	1.149	1-13/16	2.093	3/4	1-7/64	0.03~0.09	2.50	5.00
1-1/8 x 5-1/2	BN7025-112-550	1.149	1-13/16	2.093	3/4	1-7/32	0.03~0.09	2.50	5.50
1-1/4 x 6-1/2	BN7025-125-650	1.277	2	2.309	27/32	1-7/32	0.03~0.09	2.75	6.50
1-1/2 x 7	BN7025-150-700	1.531	2-3/8	2.742	1	1-15/32	0.03~0.09	3.25	7.00
1-1/2 x 7-1/2	BN7025-150-750	1.531	2-3/8	2.742	1	1-15/32	0.03~0.09	3.25	7.50
1-1/2 x 8	BN7025-150-800	1.531	2-3/8	2.742	1	1-15/32	0.03~0.09	3.25	8.00

Packaged Bolt & Nut Packs (Water Resistant)

Part No.	Class 125/150 Flange Size	Bolt Diameter and Length	No. of Bolts per Flange	No. of Bolts per Poly Bag	Master Box (Qty. of Sets)	Master Box Weight (Lbs.)
FBZ015	1	1/2 x 2	4	4	64	20
	1-1/2					
FBZ03	2	5/8 x 2-1/2	4	4	20	34
	2-1/2					
FBZ04	3	5/8 x 3	8	8	16	55
	4					
FBZ08	5	3/4 x 3-1/2	8	8	8	50
	6					
FBZ12	8	7/8 x 4	12	12	4	55
	10					
FBZ14	12	1 x 4-1/2	12	12	1	40
	14					
FBZ16	16	1 x 4-1/2	16	16	1	52
FBZ18	18	1-1/8 x 5	16	16	1	37
FBZ20	20	1-1/8 x 5	20	20	1	44
FBZ24	24	1-1/4 x 5-1/2	20	20	1	70
FBZ30	30	1-1/4 x 6-1/2	28	14	2 boxes	50
FBZ36	36	1-1/2 x 7	32	8	4 boxes	53
FBZ42	42	1-1/2 x 7-1/2	36	9	4 boxes	
FBZ48	48	1-1/2 x 8	44	11	4 boxes	

1. Heavy hex head steel bolts to ANSI B18.2.1 with heavy hex steel nuts to ANSI B18.2.2. Bolts to be threaded to ANSI B1.1 unified inch screw threads, class 2A external & Class 2B internal. The steel material to conform to ASTM A307s-pecification for carbon steel externally threaded standard fasteners, Grade B.
2. Zinc Plated per ASTM B633.

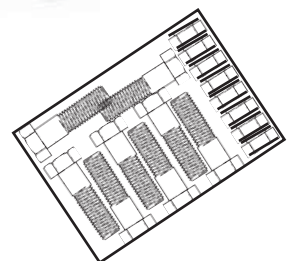

Stainless Steel Hex Bolts and Nuts For Flanges to B16.1-125#, B16.5-150# SS 304 and SS 316

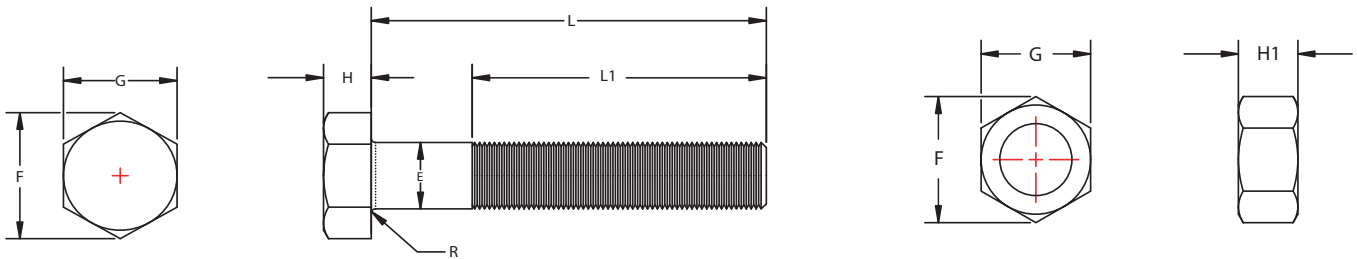

Nominal Size	Part No.	E	G	F	H	HI	R	L ₁	L
		Body Diameter	Width Across Flats	Max. Width Across Corners	Bolt Head Height	Nut Height	Radius of Fillet	Thread Length	Shaft Length
1/2 x 2	BN6025-050-200*	0.515	3/4	0.866	11/32	7/16	0.01-0.03	1.25	2.00
5/8 x 2-1/2	BN6025-062-250*	0.642	15/16	1.083	27/64	35/64	0.02-0.06	1.50	2.50
5/8 x 3	BN6025-062-300*	0.642	15/16	1.083	27/64	35/64	0.02-0.06	1.50	3.00
3/4 x 3-1/2	BN6025-075-350*	0.768	1-1/8	1.299	1/2	41/64	0.02-0.06	1.75	3.50
3/4 x 4-1/2	BN6025-075-450*	0.768	1-1/8	1.299	1/2	41/64	0.02-0.06	1.75	4.50
7/8 x 4	BN6025-082-400*	0.895	1-5/16	1.516	37/64	3/4	0.02-0.06	2.00	4.00
7/8 x 4-1/2	BN6025-082-450*	0.895	1-5/16	1.516	37/64	3/4	0.02-0.06	2.00	4.50
1 x 4-1/2	BN6025-100-450*	1.022	1-1/2	1.732	43/64	55/64	0.03-0.09	2.25	4.50
1-1/8 x 5	BN6025-112-500*	1.149	1-11/16	1.949	3/4	31/32	0.03-0.09	2.50	5.00
1-1/8 x 5-1/2	BN6025-112-550*	1.149	1-11/16	1.949	3/4	1-1/16	0.03-0.09	2.50	5.50
1-1/4 x 6-1/2	BN6025-125-650*	1.277	1-7/8	2.165	27/32	1-9/32	0.03-0.09	2.75	6.50
1-1/2 x 7	BN6025-150-700*	1.531	2-1/4	2.598	1	1-9/32	0.03-0.09	3.25	7.00
1-1/2 x 7-1/2	BN6025-150-750*	1.531	2-1/4	2.598	1	1-9/32	0.03-0.09	3.25	7.50
1-1/2 x 8	BN6025-150-800*	1.531	2-1/4	2.598	1	1-9/32	0.03-0.09	3.25	8.00

*Add suffix 304 or 316 to specify stainless steel type.

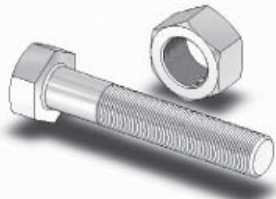

Packaged Bolt & Nut Packs (Water Resistant)

1. Hex head stainless steel bolts to ANSI B18.2.1 with hex stainless steel nuts to ANSI B18.2.2. Bolts to be threaded to ANSI B1.1 unified inch screw threads, Class 2A external & Class 2B internal. The stainless steel material is available in either Type 304 or Type 316.

Stainless Steel 304

Stainless Steel 316

Part No.	Class 125/150 Flange Size	Bolt Diameter and Length	No. of Bolts per Flange	No. of Bolts per Poly Bag	Master Box (Qty. of Sets)
FBS03-304	2 2-1/2	5/8 x 2-1/2	4	4	20
FBS04-304	3 4	5/8 x 3	8	8	16
FBS08-304	5 6	3/4 x 3-1/2	8	8	8
FBS12-304	8 10 12	7/8 x 4	12	12	4
FBS14-304	14	1" x 4-1/2"	12	12	1
FBS16-304	16	1" x 4-1/2"	16	16	1
FBS18-304	18	1-1/8" x 5"	16	16	1
FBS20-304	20	1-1/8" x 5"	20	20	1
FBS24-304	24	1-1/4" x 5-1/2"	20	20	1
FBS30-304	30	1-1/4" x 6-1/2"	28	14	2 boxes
FBS36-304	36	1-1/2" x 7"	32	8	4 boxes

Part No.	Class 125/150 Flange Size	Bolt Diameter and Length	No. of Bolts per Flange	No. of Bolts per Poly Bag	Master Box (Qty. of Sets)
FBS03-316	2 2-1/2	5/8 x 2-1/2	4	4	20
FBS04-316	3 4	5/8 x 3	8	8	16
FBS08-316	5 6	3/4 x 3-1/2	8	8	8
FBS12-316	8 10 12	7/8 x 4	12	12	4
FBS14-316	14	1" x 4-1/2"	12	12	1
FBS16-316	16	1" x 4-1/2"	16	16	1
FBS18-316	18	1-1/8" x 5"	16	16	1
FBS20-316	20	1-1/8" x 5"	20	20	1
FBS24-316	24	1-1/4" x 5-1/2"	20	20	1
FBS30-316	30	1-1/4" x 6-1/2"	28	14	2 boxes
FBS36-316	36	1-1/2" x 7"	32	8	4 boxes

Stud Bolts/Nuts

STUD BOLTS				NUTS			
Bolt Size	Part No. Zinc Plated (B7)	Part No. SS304	Part No. SS316	Nut Size	Part No. Zinc Plated (2H)	Part No. SS304	Part No. SS316
1/2" x 2"	8025-050-200	8025-050-200-304	8025-050-200-316	1/2"	8035-050	8035-050-304	8035-050-316
5/8" x 2-1/2"	8025-062-250	8025-062-250-304	8025-062-250-316	5/8"	8035-062	8035-062-304	8035-062-316
5/8" x 3"	8025-062-300	8025-062-300-304	8025-062-300-316				
5/8" x 3-1/2"	8025-062-350	8025-062-350-304	8025-062-350-316				
5/8" x 6"	8025-062-600	8025-062-600-304	8025-062-600-316				
3/4" x 3"	8025-075-300	8025-075-300-304	8025-075-300-316	3/4"	8035-075	8035-075-304	8035-075-316
3/4" x 3-1/2"	8025-075-350	8025-075-350-304	8025-075-350-316				
3/4" x 4"	8025-075-400	8025-075-400-304	8025-075-400-316				
3/4" x 4-1/2"	8025-075-450	8025-075-450-304	8025-075-450-316				
3/4" x 5"	8025-075-500	8025-075-500-304	8025-075-500-316				
3/4" x 5-1/2"	8025-075-550	8025-075-550-304	8025-075-550-316				
3/4" x 6"	8025-075-600	8025-075-600-304	8025-075-600-316				
3/4" x 7"	8025-075-700	8025-075-700-304	8025-075-700-316				
7/8" x 3-1/2"	8025-082-350	8025-082-350-304	8025-082-350-316	7/8"	8035-082	8035-082-304	8035-082-316
7/8" x 3-3/4"	8025-082-375	8025-082-375-304	8025-082-375-316				
7/8" x 8"	8025-082-800	8025-082-800-304	8025-082-800-316				
1" x 4"	8025-100-400	8025-100-400-304	8025-100-400-316	1"	8035-100	8035-100-304	8035-100-316
1" x 5"	8025-100-500	8025-100-500-304	8025-100-500-316				
1" x 6"	8025-100-600	8025-100-600-304	8025-100-600-316				
1-1/8" x 4-1/2"	8025-112-450	8025-112-450-304	8025-112-450-316	1-1/8"	8035-112	8035-112-304	8035-112-316
1-1/8" x 5"	8025-112-500	8025-112-500-304	8025-112-500-316				
1-1/4" x 5"	8025-125-500	8025-125-500-304	8025-125-500-316				
1-1/4" x 6"	8025-125-600	8025-125-600-304	8025-125-600-316	1-1/4"	8035-125	8035-125-304	8035-125-316
1-1/4" x 7"	8025-125-700	8025-125-700-304	8025-125-700-316				
1-1/2" x 6"	8025-150-600	8025-150-600-304	8025-150-600-316	1-1/2"	8035-150	8035-150-304	8035-150-316
1-1/2" x 7"	8025-150-700	8025-150-700-304	8025-150-700-316				

Material:

Bolts:
Zinc Plated Steel, Grade B7
Stainless Steel 304
Stainless Steel 316

Nuts:
Zinc Plated Steel, Grade 2H
Stainless Steel 304
Stainless Steel 316



Packaged Flange Stud Bolt Packs for use with Class 125/150 Flange Pipe

Part No. B7, 2H	Part No. SS304	Part No. SS316	Flange Size	Bolt Size	No. of Bolts/ Nuts per Flange	No. of Bolts/ Nuts per Polybag	Master Box (No. of Packs)
FSB03	FSB03-304	FSB03-316	2"	5/8" x 3"	4	4	20
			2-1/2"				
			3"				
FSB04	FSB04-304	FSB04-316	4"	5/8" x 3"	8	8	16
FSB08	FSB08-304	FSB08-316	5"	3/4" x 3-1/2"	8	8	8
			6"				
			8"				
FSB12	FSB12-304	FSB12-316	10"	7/8" x 3-1/2"	12	12	4
			12"				
FSB14	FSB14-304	FSB14-316	14"	1" x 4"	12	12	1
FSB16	FSB16-304	FSB16-316	16"	1" x 4"	16	16	1
FSB18	FSB18-304	FSB18-316	18"	1-1/8" x 4-1/2"	16	16	1
FSB20	FSB20-304	FSB20-316	20"	1-1/8" x 4-1/2"	20	20	1
FSB24	FSB24-304	FSB24-316	24"	1-1/4" x 5"	20	20	1
FSB30	FSB30-304	FSB30-316	30"	1-1/4" x 5"	28	14	2 boxes (1pack each box)
FSB36	FSB36-304	FSB36-316	36"	1-1/2" x 6"	32	8	4 boxes (1pack each box)
FSB42	FSB42-304	FSB42-316	42"	1-1/2" x 6"	36	9	4 boxes (1pack each box)
FSB48	FSB48-304	FSB48-316	48"	1-1/2" x 7"	44	11	4 boxes (1pack each box)

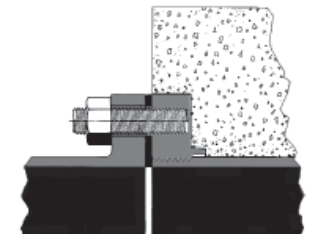

FLANGE DETAILS - Class 250

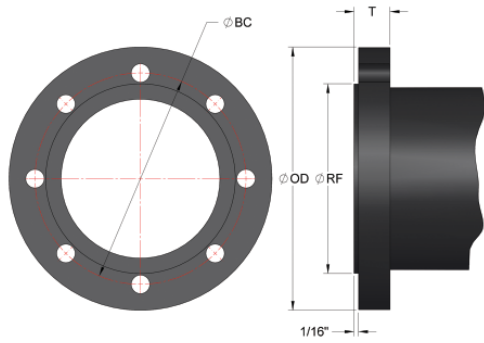

Size	OD	T	RF	BC	Bolt Hole Dia.	Bolt Dia. & Length	No. of Bolts
3	8-1/4	1.12	5-11/16	6-5/8	7/8	3/4 x 3-1/2	8
4	10	1.25	6-15/16	7-7/8	7/8	3/4 x 3-3/4	8
5	11	1.38	8-5/16	9-1/4	7/8	3/4 x 4	8
6	12-1/2	1.44	9-11/16	10-5/8	7/8	3/4 x 4	12
8	15	1.62	11-15/16	13	1	7/8 x 4-1/4	12
10	17-1/2	1.88	14-1/16	15-1/4	1-1/8	1 x 5-1/4	16
12	20-1/2	2.00	16-7/16	17-3/4	1-1/4	1-1/8 x 5-1/2	16

ELBOWS

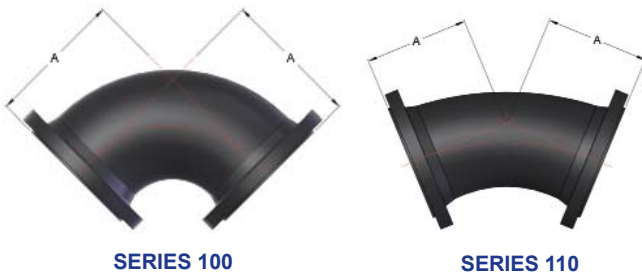

Size	90° Elbow			45° Elbow		
	Part No.	A	Wgt.	Part No.	A	Wgt.
3	100F-0303-	6	40	110F-0303-	3-1/2	35
4	100F-0404-	7	66	110F-0404-	4-1/2	60
6	100F-0606-	8-1/2	124	110F-0606-	5-1/2	103
8	100F-0808-	10	192	110F-0808-	6	158
10	100F-1010-	11-1/2	311	110F-1010-	7	247
12	100F-1212-	13	430	110F-1212-	8	355

90° REDUCING ELBOW



Size	Part No.	A	Weight
6 x 4	100F-0604-	8-1/2	95
8 x 6	100F-0806-	10	161
10 x 8	100F-1008-	11-1/2	240

TEES

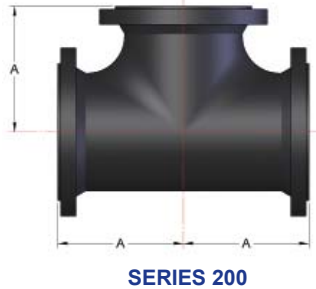

Size	Part No.	A	Weight
3	200F-0303-	6	58
4	200F-0404-	7	98
6	200F-0606-	8-1/2	184
8	200F-0808-	10	280
10	200F-1010-	11-1/2	435
12	200F-1212-	13	599

REDUCING TEES



Size	Part No.	A	Weight
6 x 6 x 4	200F-0604-	8-1/2	150
8 x 8 x 6	200F-0806-	10	246
10 x 10 x 6	200F-1006-	11-1/2	375
10 x 10 x 8	200F-1008-	11-1/2	405
12 x 12 x 6	200F-1206-	13	435
12 x 12 x 8	200F-1208-	13	445

Add suffix "C" for Grey Cast Iron - "D" for Ductile Cast Iron

Larger sizes thru 48" available upon request.

REDUCERS (Concentric/Eccentric)

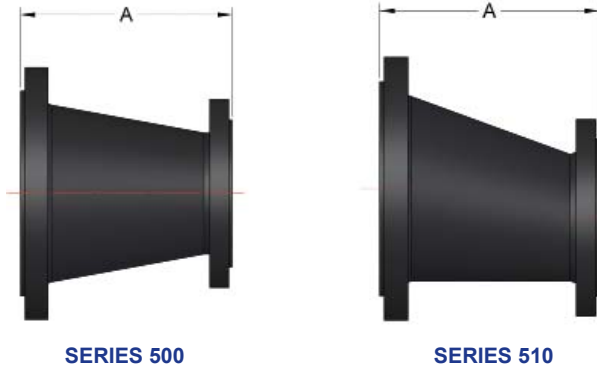

Size	Part No. (Concentric)	Part No. (Eccentric)	A	Weight
4 x 3	500F-0403-	510F-0403-	7	40
6 x 3	500F-0603-	510F-0603-	9	70
6 x 4	500F-0604-	510F-0604-	9	77
6 x 5	500F-0605-	510F-0605-	9	85
8 x 5	500F-0805-	510F-0805-	11	135
8 x 6	500F-0806-	510F-0806-	11	142
10 x 6	500F-1006-	510F-1006-	12	185
10 x 8	500F-1008-	510F-1008-	12	196
12 x 6	500F-1206-	510F-1206-	14	235
12 x 8	500F-1208-	510F-1208-	14	260
12 x 10	500F-1210-	510F-1210-	14	275

BLIND FLANGES

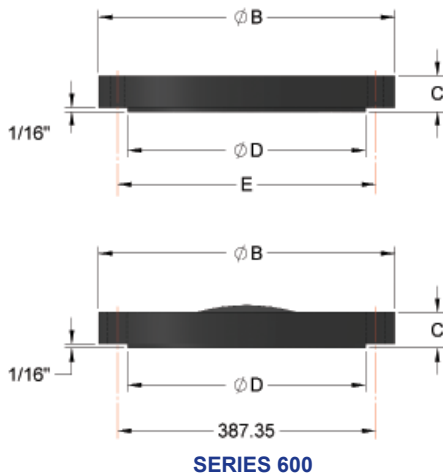

Nominal Pipe Size	Flange Size	Part No.	C	B	D	E	Weight
3	3 x 8-1/4	600F-0303-	1-3/16	8-1/4	5-11/16	6-5/8	14
4	4 x 10	600F-0404-	1-1/4	10	6-15/16	7-7/8	25
6	6 x 12-1/2	600F-0606-	1-7/16	12-1/2	9-11/16	10-5/8	43
8	8 x 15	600F-0808-	1-5/8	15	1-15/16	13	69
10	10 x 17-1/2	600F-1010-	1-7/8	17-1/2	14-1/16	15-1/4	100
12	12 x 20-1/2	600F-1212-	2	20-1/2	16-7/16	17-3/4	148

Dished faces for use with 10" and 12" extra heavy Blind Flanges.

THREADED FLANGES

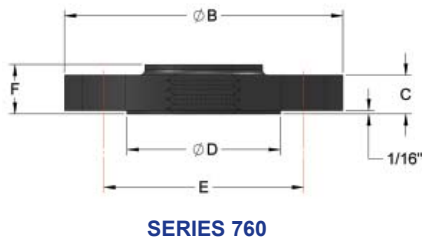

Nominal Pipe Size	Flange Size	Part No.	C	B	D	E	F	Weight
1	1 x 4-7/8	760-0100-0488-	11/16	4-7/8	2-11/16	3-1/2	7/8	3
1-1/4	1-1/4 x 5-1/2	760-0125-0525-	3/4	5-1/4	3-1/16	3-7/8	1	4
1-1/2	1-1/2 x 6-1/8	760-0150-0612-	13/16	6-1/8	3-5/16	4-1/2	1-1/8	6
2	2 x 6-1/2	760-0200-0650-	7/8	6-1/2	4-3/16	5	1-3/4	7
2-1/2	2-1/2 x 7-1/2	760-0250-0750-	1	7-1/2	4-15/16	5-7/8	1-7/16	10
3	3 x 8-1/4	760-0300-0825-	1-1/8	8-1/4	5-11/16	6-5/8	1-11/16	12.8
4	4 x 10	760-0400-1000-	1-1/4	10	6-15/16	7-7/8	1-3/4	22.5
6	6 x 12-1/2	760-0600-1250-	1-7/16	12-1/2	9-11/16	10-5/8	1-15/16	34.2
8	8 x 15	760-0800-1500-	1-5/8	15	11-15/16	13	2-3/16	55
10	10 x 17-1/2	760-1000-1750-	1-7/8	17-1/2	14-1/16	15-1/4	2-3/8	77
12	12 x 20 -1/2	760-1200-2050-	2	20-1/2	16-7/16	17-3/4	2-9/16	103

Add suffix "C" for Grey Cast Iron - "D" for Ductile Cast Iron

Larger sizes thru 48" available upon request.



c **UL** **US**
LISTED

UNITED Water Products

2113 W. 30th Street
Jacksonville, FL 32209
Tel: 877-766-4459
Fax: 877-766-4458
www.unitedwaterproducts.com

FFB16.0317